

10' X 10' LINEAR ASSEMBLY INSTRUCTIONS

1. ASSEMBLE FRAME (PAGE 2,DETAIL 1)
2. ATTACH COUNTERTOP & PEDESTAL ASSEMBLIES (PAGE 3, DETAIL 4)
3. ATTACH STANDOFFS AND PLEX WINGS (PAGE 4, DETAIL 5)
4. ATTACH PLEX GRAPHIC HEADER (PAGE 4, DETAIL 6)
5. ATTACH MONITOR BRACKET & MONITOR. (PAGE 4,DETAIL 7)
6. ATTACH COUNTERTOP & PEDESTAL (PAGE 5)

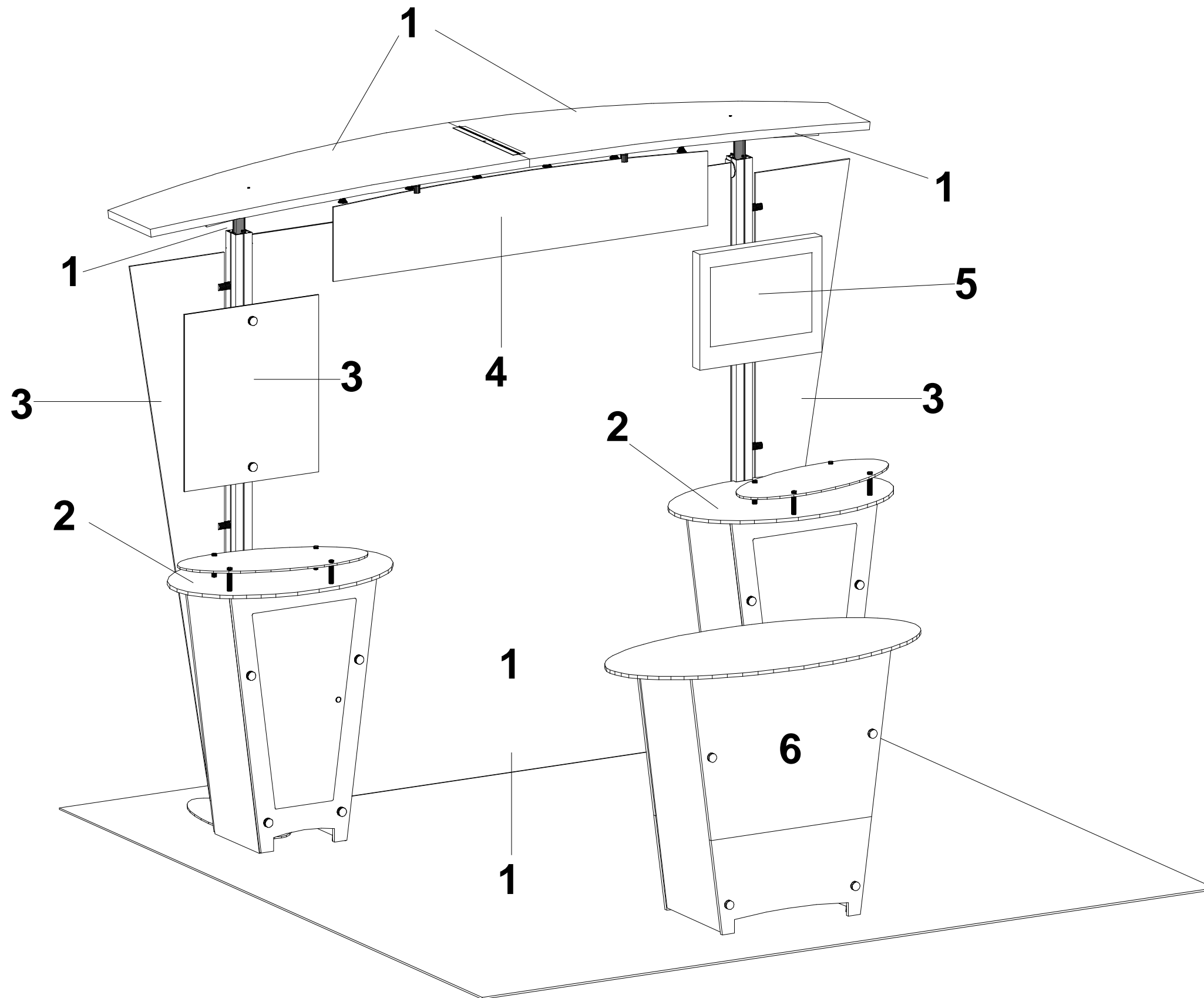

NOTICE

This set-up configuration, as explicitly depicted in these drawings, is considered to be stable by EXPONENTS, INC. The user assumes all risks for any deviation from these drawings. EXPONENTS, INC. will assume no liability for any variation from these drawings without prior written approval. CAUTION should be taken to assure that conditions at the installation site, and/or additions to the structure do not cause instability. Factors that may cause instability include, but are not limited to, the condition of the surface on which the structure is assembled, and the attachment to, or placement on, the structure of products, equipment, or fixtures.



EXPONENTS

DWG 1 OF 5 # 20948

DEALER: THE EXHIBIT SOURCE
CLIENT: ORGANOGENESIS/APLIGRAF
DESCRIPTION: 10' X 10' EXHIBIT
SCALE: NO SCALE
DATE: 100404
BY: HN

EMERGENCY HARDWARE NUMBER
1-800-451-4723 IN CA 619-298-6473

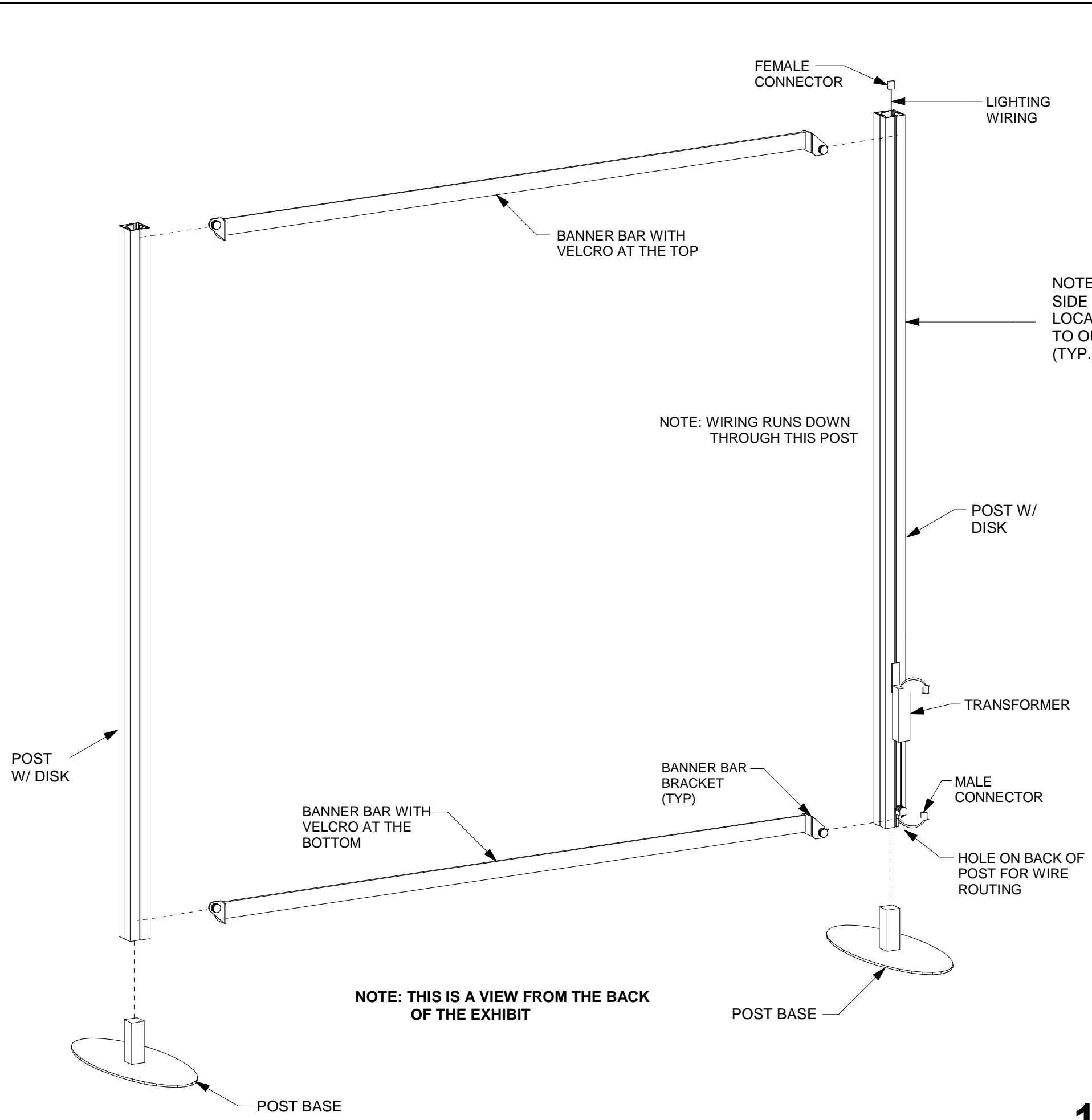

FRAME ASSEMBLY INSTRUCTIONS

1. LAY POSTS ON FLOOR.
2. ON BANNER BAR BRACKET, BACK "T" OUT BY 1/2". (SEE DRAWING BELOW) PLACE BANNER BAR BRACKETS AGAINST BACK OF POST. (DETAIL 1)
3. PLACE BRACKETS THAT ARE AT THE TOP OF POSTS SO THAT THE TOP OF THE BRACKET IS FLUSH WITH THE TOP OF THE POST.
4. INSERT "T" INTO POST SLOT, THEN USING THE KNOB, TURN "T" TO THE RIGHT APPROX. 20 DEGREES AND TIGHTEN. (FINGER TIGHTEN ONLY)
5. PLACE POST BASES ON TO THE BOTTOM OF THE POSTS WHILE STILL LAYING ON THE FLOOR.
6. ASSEMBLE CANOPY AND PLACE IN POSITION ON THE TOP OF THE POSTS WHILE STILL LAYING ON THE FLOOR, (PAGE 3,DETAIL 2) AND ATTACH HEADER GRIPPERS (PAGE 4,DETAIL 6)
7. STAND FRAME ASSEMBLY UP AND SET IN POSITION.
8. ATTACH TRANSFORMER AND LIGHTING (PAGE 3,DETAIL 3)
9. ATTACH BANNER TO TOP BANNER BAR.
10. ATTACH BANNER TO BOTTOM BAR AND PULL TAUT.

ASSEMBLY INSTRUCTIONS

1. PLACE BANNER BAR BRACKETS AGAINST BACK OF POST.
2. PLACE BRACKETS THAT ARE AT THE TOP OF POSTS SO THAT THE TOP OF THE BRACKET IS FLUSH WITH THE TOP OF THE POST.
3. BACK OUT "T" BY 1/2" (SEE DRAWING BELOW). INSERT "T" INTO POST SLOT, THEN USING THE KNOB, TURN "T" TO THE RIGHT APPROX. 20 DEGREES AND TIGHTEN. (FINGER TIGHTEN ONLY)

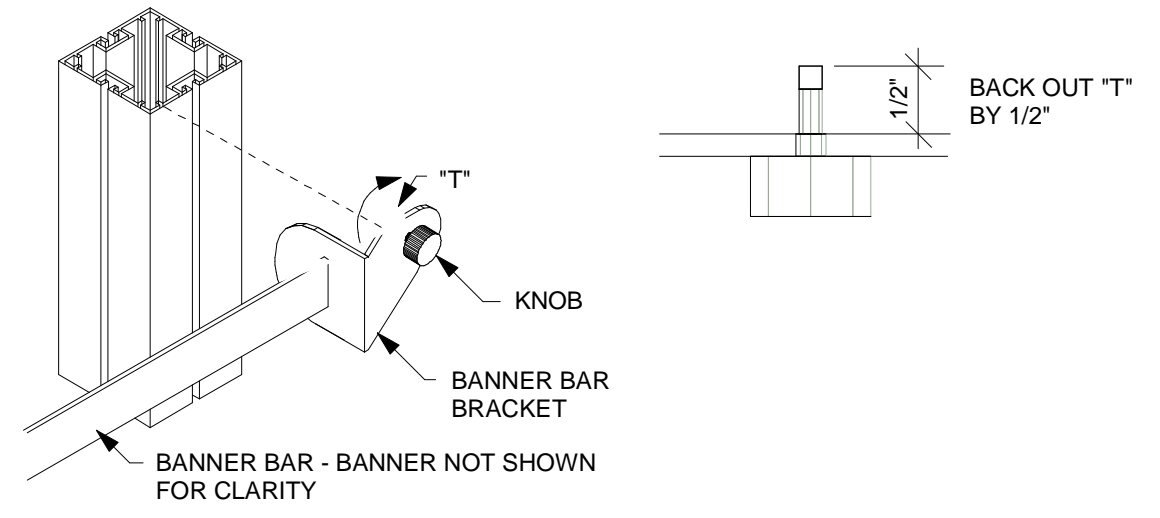

NOTE: MAKE SURE BANNER IS PULLED TAUT WHEN TIGHTENING BANNER BAR BRACKETS AT POSTS.

1 TYPICAL BANNER BAR ATTACHMENT TO

**NOTE: DO NOT ATTEMPT TO TAKE
THREADED LUGS OUT OF
PLATES WHEN DISMANTLING
EXHIBIT.**

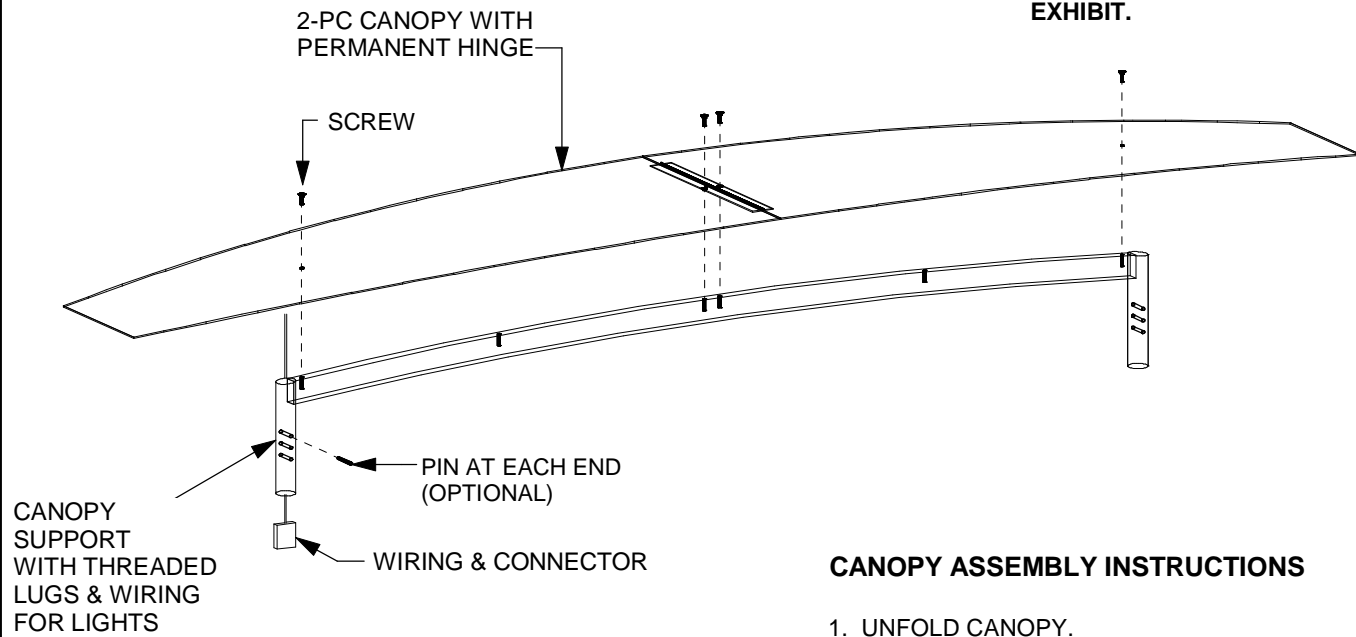

CANOPY ASSEMBLY INSTRUCTIONS

1. UNFOLD CANOPY.
2. ATTACH CANOPY TO CANOPY SUPPORT, PLUG WIRING CONNECTORS TOGETHER
3. PLACE CANOPY ASSEMBLY INTO POSTS, PLUG WIRING CONNECTORS TOGETHER.

2 CANOPY ATTACHMENT TO CANOPY SUPPORT

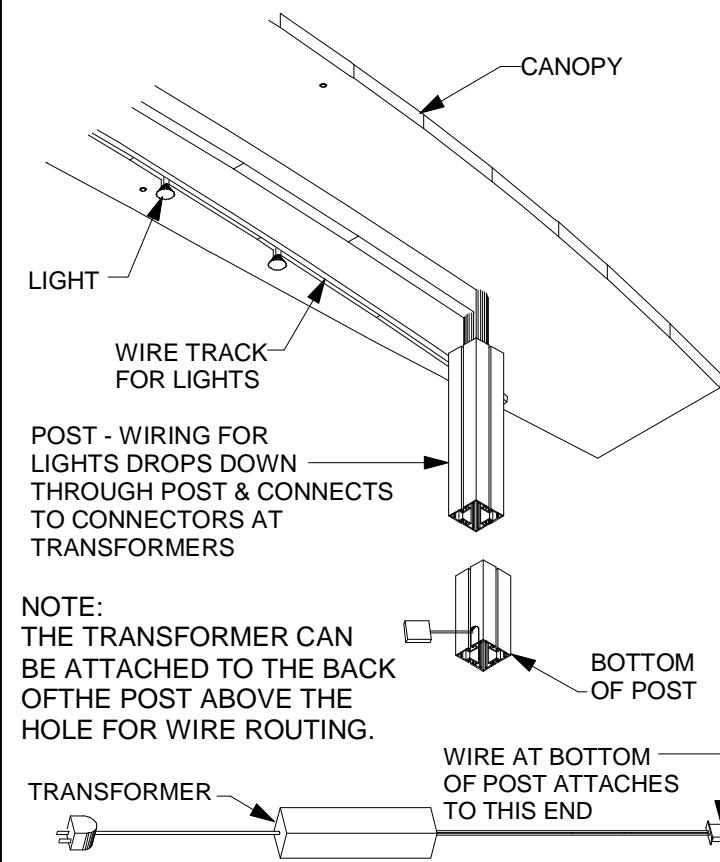

ATTACHMENT INSTRUCTIONS

1. PLACE CONNECTOR ON TRACK SO THAT METAL PRONGS ARE NEXT TO TRACK SIDES.
2. PUSH SLIDING PLASTIC HOUSING UP TO FASTEN CONNECTOR TO TRACK.
3. REVERSE THE ABOVE STEPS TO REMOVE FROM TRACK.

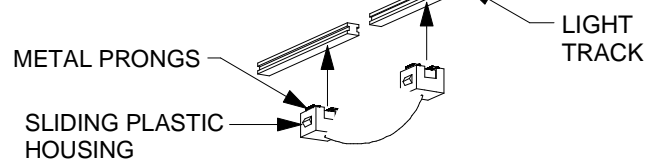

JUMPER ATTACHMENT TO LIGHT TRACK

ATTACHMENT INSTRUCTIONS

- PUSH FIXTURE UP ONTO LIGHT TRACK, PULL DOWN TO REMOVE

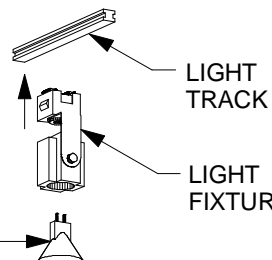

LIGHT ATTACHMENT TO LIGHT TRACK

3 VIEW FROM RIGHT REAR OF EXHIBIT

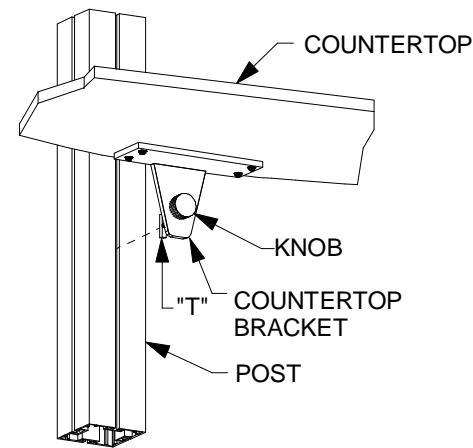

COUNTERTOP ATTACHMENT TO POST

ASSEMBLY INSTRUCTIONS

1. ATTACH FRONT AND BACK PANELS TO THE BONDED METAL SIDE PANELS WITH STANDOFF CAPS.
2. SET SHELVES IN PLACE.
3. ATTACH COUNTERTOP TO CABINET.
4. ON COUNTERTOP BRACKET, BACK "T" OUT BY 1/2". PLACE COUNTERTOP BRACKET WITH COUNTERTOP AGAINST POST.
5. INSERT "T" END OF KNOB IN COUNTERTOP BRACKET INTO POST SLOT.
6. TURN "T" IN SLOT APPROX. SLOT, TIGHTEN KNOB (FINGER TIGHTEN ONLY)

COLORS:

COUNTERTOP - SILVER PHENOLIC
DOOR & BACK PANEL - SILVER ALUMINIUM METALX
SIDE PANELS - ALUMINIUM
SHELVES - BLACK

NOTE: DO NOT USE SCREWS LONGER THAN 3/8" TO SCREW PEDESTAL TO COUNTERTOP.

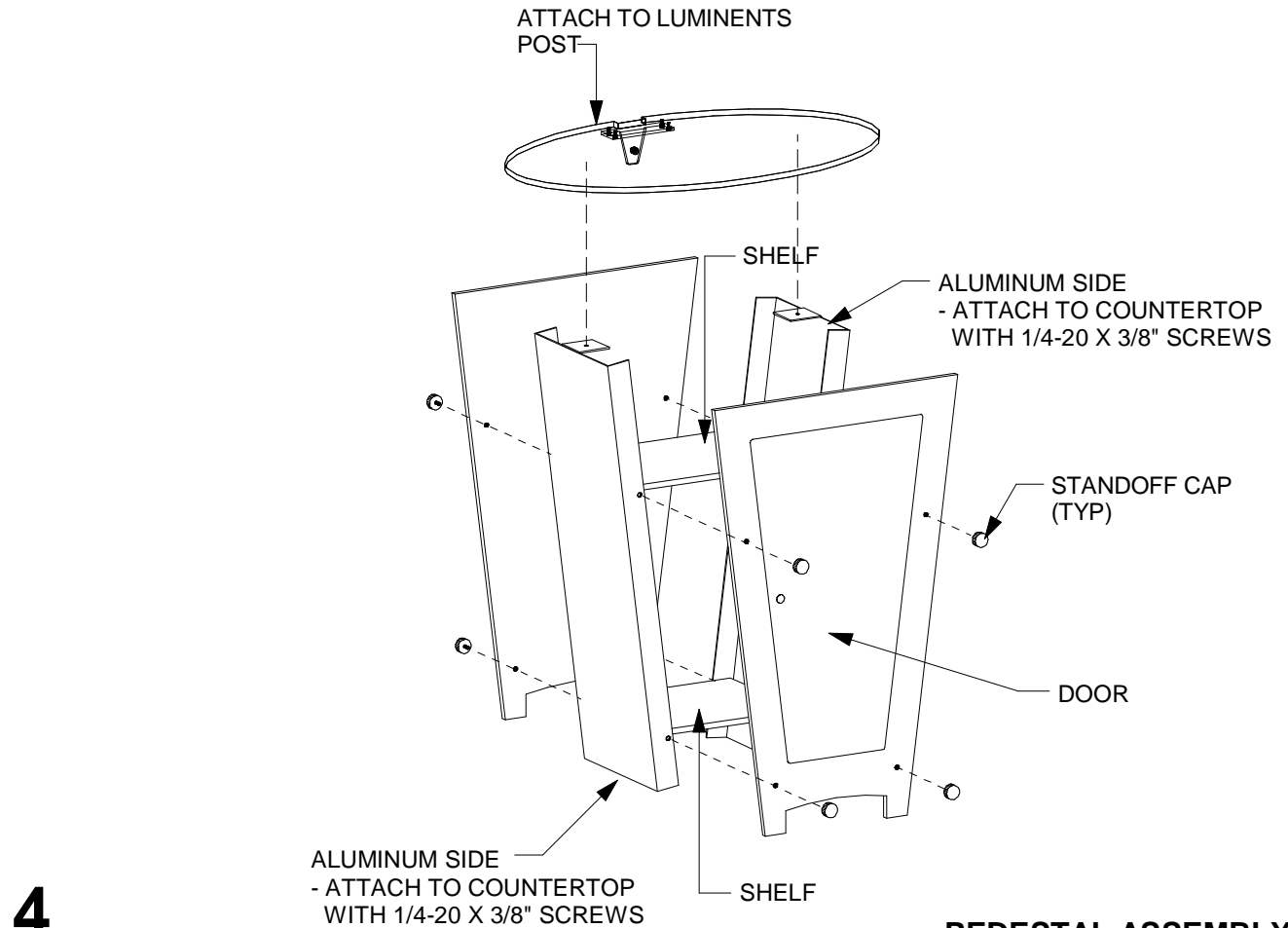

4

PEDESTAL ASSEMBLY

1. ATTACH STANDOFF WITH CAP TO WING
(LEAVE LOOSE -DO NOT TIGHTEN YET)
2. BACK "T" OUT BY 1/2". INSERT "T" END INTO POST SLOT, TURN "T" APPROX. 20 DEGREES IN SLOT AND TIGHTEN STANDOFF AGAINST POST.
(FINGER TIGHTEN ONLY)
3. TIGHTEN CAP AGAINST WING

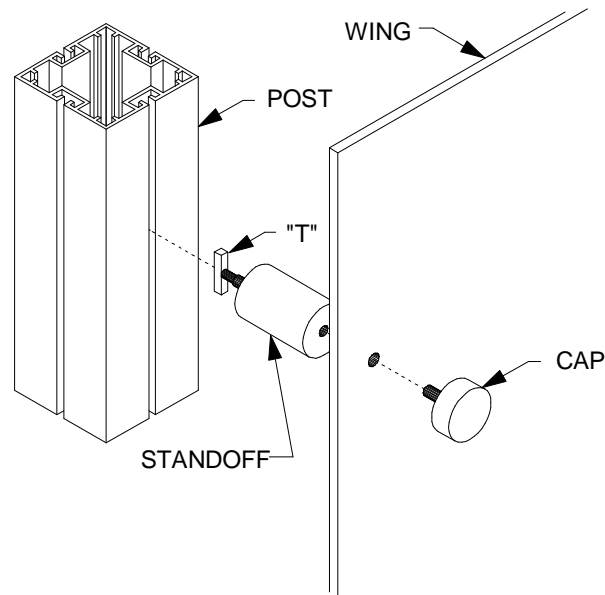

1. BACK "T" OUT BY 1/2". INSERT "T" END OF STANDOFF INTO POST SLOT, TURN "T" APPROX. 20 DEGREES IN SLOT AND TIGHTEN NUT.
(FINGER TIGHTEN ONLY)
2. INSERT WING INTO GRIPPER SLOT & TIGHTEN SET SCREW WITH HEX KEY.

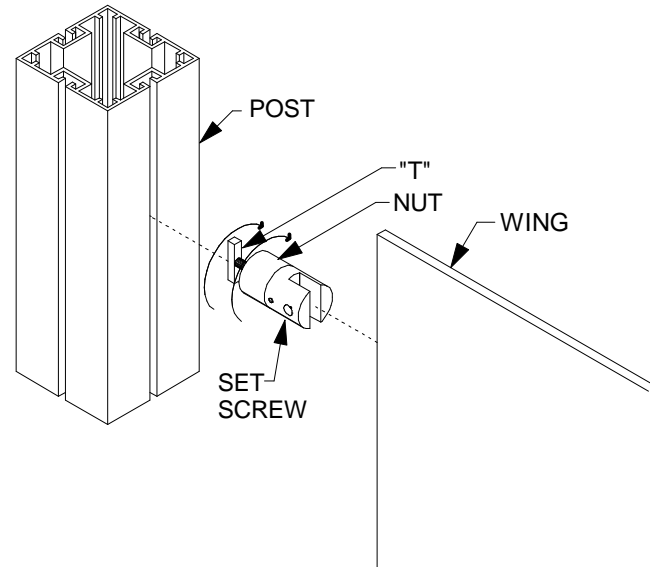

SIDE MOUNT WING ATTACHMENT AT POST - GRIPPER STANDOFF
NOTE: 3 GRIPPER STANDOFFS REQUIRED

5 FRONT MOUNT WING ATTACHMENT AT POST

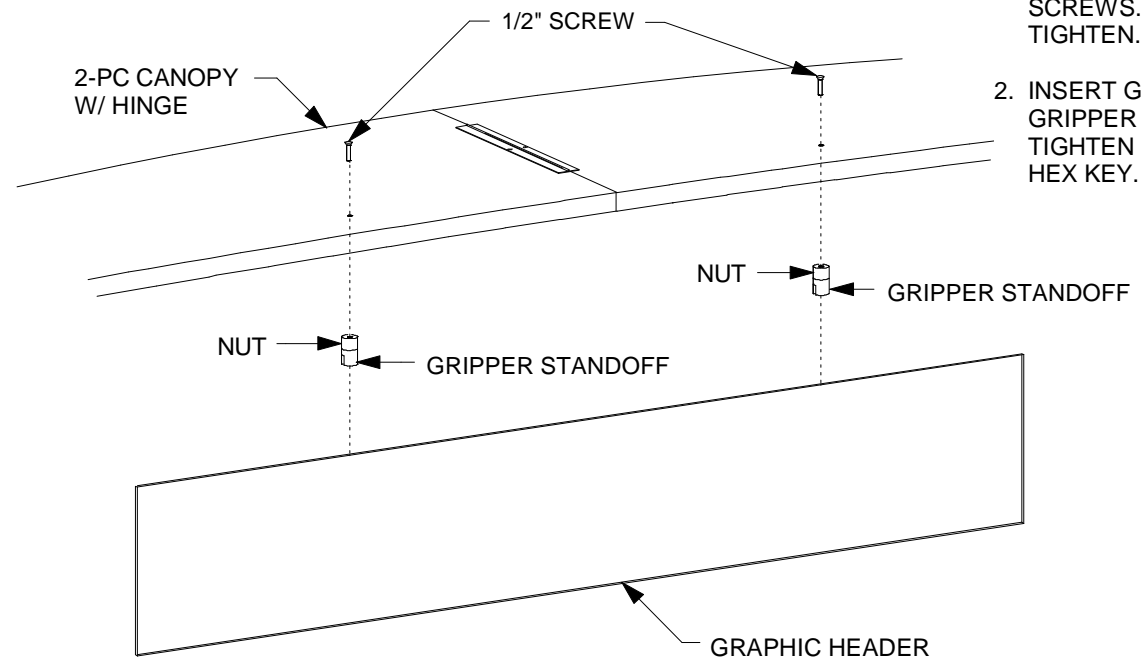

ASSEMBLY INSTRUCTIONS:

1. ATTACH GRIPPER STANDOFF TO CEILING OF CANOPY USING SCREWS. TURN NUT TO TIGHTEN. (FINGER TIGHTEN ONLY)
2. INSERT GRAPHIC INTO GRIPPER STANDOFF AND TIGHTEN SET SCREW WITH HEX KEY.

6 GRAPHIC HEADER ATTACHMENT TO CANOPY

ASSEMBLY INSTRUCTIONS

1. BACK "T" OUT BY 1/2".
2. PLACE MOUNTING PLATE WITH MONITOR BRACKET ATTACHED AGAINST POST SO THAT THE "T" END OF KNOBS FIT INTO POST SLOT.
3. TURN KNOB APPROX. 20 DEGREES IN POST SLOT. TIGHTEN.

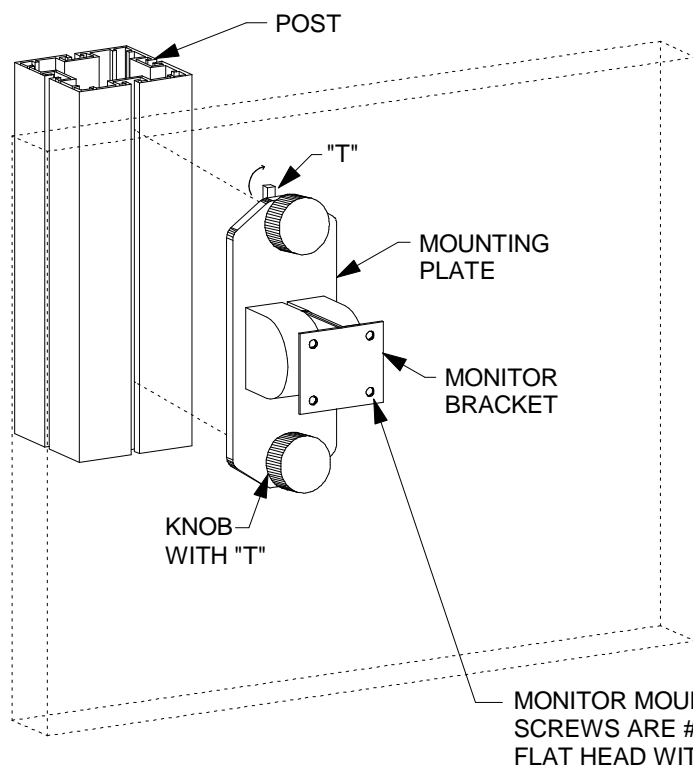

7 MONITOR MOUNTING BRACKET ATTACHMENT TO POST

NOTE: DO NOT USE A LONGER SCREW THAN 1/4-20 X 3/8"
TO ATTACH ALUMINUM SIDES TO COUNTERTOP.

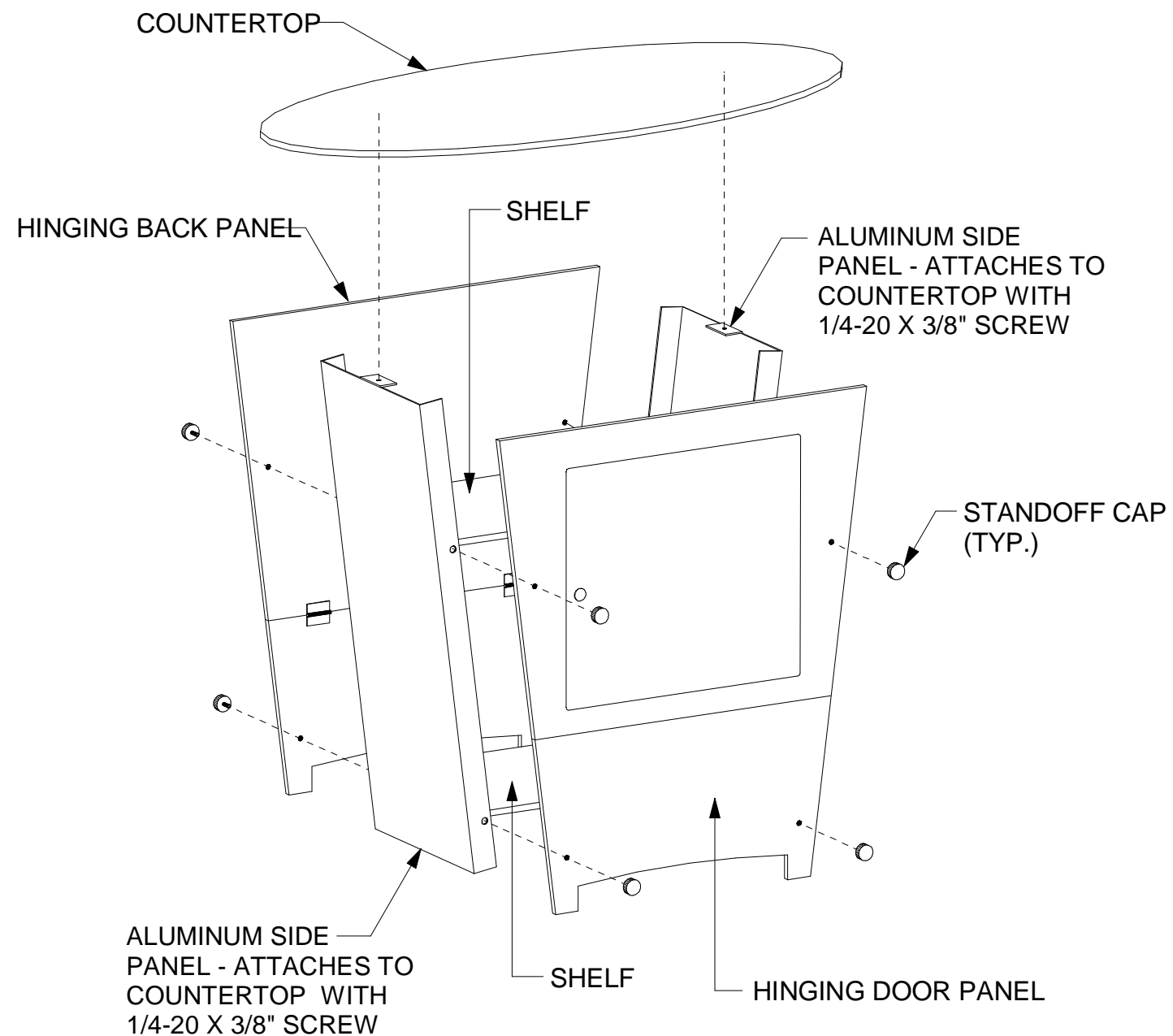

ASSEMBLY INSTRUCTION

1. ATTACH FRONT AND BACK PANELS TO THE BONDED METAL SIDE PANELS WITH STANDOFF CAPS.
2. SET SHELVES IN PLACE.
3. ATTACH COUNTERTOP TO CABINET.

COLORS:

COUNTERTOP - SILVER PHENOLIC
DOOR & BACK PANEL - SILVER ALUMINUM METALX
SIDE PANELS - ALUMINUM
SHELVES - BLACK

PEDESTAL & COUNTERTOP
(LC07)

